

STATUS OF STATISTICS

An analysis, as of the 10th of this month, of the current pricing and inventory status trends in the TVRO industry. Users of this data are warned that CJR 'samples' key OEMs and distributors on the 10th of each month to determine trends and averages. Dealers will find this data useful in planning their own purchasing schedules for the coming 30 day period.

CURRENT PRICING/LNAs

For 100 degree LNAs, 50 dB gain, CWO terms, 3 lot purchase.

- 1) Lowest price reported: _____ \$275.00
- 2) Highest price recorded: _____ \$360.00
- 3) Average price recorded: _____ \$314.00

CURRENT SHIPMENT/LNAs

- 1) Greatest decline reported: _____ even (0) %
- 2) Greatest increase reported: _____ +30 %
- 3) Average 30 day change: _____ +10 %

CURRENT PRICING/ANTENNAS

- 1) Percentage reporting price declines _____ -10 %
- 2) Percentage reporting price advances _____ none %
- 3) Average 30 day change: _____ -1%

CURRENT SHIPMENTS/ANTENNAS

- 1) Greatest decline reported: _____ -15 %
- 2) Greatest advance reported: _____ even (0) %
- 3) Average 30 day change: _____ -1 %

CURRENT PRICING/RECEIVERS

- 1) Percentage reporting price declines: _____ 20 %
- 2) Percentage reporting price advances: _____ 0 %
- 3) Average 30 day change: _____ -2 %

CURRENT SHIPMENTS/RECEIVERS

- 1) Greatest decline reported: _____ -5 %
- 2) Greatest advance reported: _____ +50 %
- 3) Average 30 day change: _____ +14 %

EARLY WARNING (Next 30 days)

- 1) Equipment shortages predicted: _____ none
- 2) Equipment surplus predicted: _____ none
- 3) Biggest downward price move: _____ none
- 4) Biggest upward price move: _____ none

In surveying individual OEMs and distributors for the 'raw data' that goes into the above monthly summary, CJR pledges complete anonymity to its 'sources'. Dealers are asked NOT to contact CJR for information on 'lowest pricing' or 'greatest declines' referenced here; our pledge to sources is unbreakable! Many issues of CJR do, however, contain 'insert flier' sheets from OEMs and distributors announcing (as in advertising) current marketing specials.

AUGUST 1983

- 14 picas -

STATS	page 1
KEEPING UP	page 2
MARKETING	page 3
INSIDER	page 6
SERVICE	page 8

8 May

MID MONTH MEMO

14 picas

GALAXY ONE is on the air! There may be more to the announcement than meets your quick look at 134 west. HBO is seriously looking at using up to six transponders for a 4 GHz 'DBS' service to 6/7 foot dish antennas; as reported in some detail in forthcoming (September) issue of **CSD**. There's more good news; initial tests by Hughes tell us that actual on-ground signal levels at least in west coast area are from 1.5 to 2 dB stronger than Hughes had expected.

12 GHz terminals may be as scarce this fall as the programming that is supposed to be coming from 12 GHz early-programmers. But stand by for next fall; NEC has given written commitment to ship no fewer than 200,000 1.2 meter terminals into USA at \$581 price starting March of 84. Oh yes; they are also claiming 2.5 dB noise figure for their new package, a substantial improvement from other 3.5 dB offerings.

Business slow? Not to worry. Almost all distributors report o.k. shipments in July, but expect big upturn starting last week of this month. Too much heatwave and too many buyers dangling their feet in the pool! Fall TV viewing is just ahead.

32 May

Cooper
James
Report

CJR/ (The) Cooper James Report is published and AIRmailed on the 15th of each month by **CJR Limited**, a Turks & Caicos Corporation with Corporate offices at Tower Plaza, Providenciales, Turks & Caicos Islands, BVI. All subscription requests, advertising requests should be directed to **CJR, P.O. Box 100858, Ft. Lauderdale, FL 33310** (call 305/771-0505 between 9AM and 4PM weekdays). An additional editorial office is maintained in Tulsa, Oklahoma (P.O. Box D, Claremore, Ok. 74017; telephone 918/342-1911) where Larry James may be reached. Subscription price is \$35 per year, AIRmail, within USA, Canada and Mexico; in US funds only. Elsewhere \$45 per year in US funds only. Sample copy available for \$5 in US funds. Material contained herein is considered **confidential** in nature and is for the study and use of TVRO dealers, distributors and OEMs only. Photocopying or extracting contents is prohibited without permission; copyright © by CJR Limited 1983/1984.

NEW PRODUCTS/ SERVICES/ APPOINTMENTS

ACCESSORIES

ICM Video (405/232-5808; P.O. Box 26330, Oklahoma City, Ok. 73126) announces automatic **video** (baseband) **processor** model VP-300C. Unit regenerates sync, blanking, color burst signals (replacing noisy signals with new reference signals) and has video AGC to maintain 1 volt peak to peak output. Also included is back porch clamping, copyguard stabilizer, 4 video and 4 audio outputs. Price is \$349.95 retail.

ICM Video announces model VE-200C **video enhancer**; a completely automatic video processing amplifier that regenerates sync and color burst signals, provides back porch clamp, color level set, video level set and burst phase control. Unit also provides delay-line video enhancement, noise reduction, copyguard stabilizer and 4 video/4 audio outputs. Price \$495 retail.

Leaming Industries (714)/979-4511; 180 McCormick Av., Costa Mesa, Ca. 92626) announces model FMU 616 D '**Disney Channel Stereo Processor**'. Unit demodulates two subcarriers (5.8 and 6.8), combines them in a stereo multiplexer and adds stereo 19 kHz pilot carrier. The output signal is frequency translated to any FM channel in the 88-108 MHz band for carriage on SMATV systems. A similar package is available for '**The Nashville Network**' and two or more stereo packages are rack mountable in their PMS-600 high density mainframe.

ANTENNAS

Pico Satellites (315-451-7700; 103 Commerce Blvd., Liverpool, NY 13088) announces model SAR-14, a **4.2 meter** satellite antenna with claimed efficiency of 68%, 3 dB beam width 1.27° and first sidelobes -20dBi. Polar over azimuth and tripod polar mounts offered; range testing patterns available (contact Jim Milne).

Regency Electronics (317-545-4281, 7707 Records St., Indianapolis, In. 46226) announces model SA 9000 antenna; **90" diameter**,

.090 marine grade hard alloy spun aluminum. Includes button-hook feed support, Polarotor feed and pole mount. Price is \$595 (retail). Contact Marc Diebold.

LNAs

California Amplifier (805/499-8535; 3481 Old Conejo Rd., A3, Newbury Park, Ca 91320) has announced a new line of 'low cost' 50/53 dB gain 120 degree LNAs. The new product is designed to be price competitive with lower gain 120 degree units now being offered in the marketplace and is an addition to the 70 through 100 degree units (plus isolated 2 and 4 way power dividers) in the line.

Mounts

Centauri Tower, Inc. (605/332-3514; P.O. Box 855, Sioux Falls, SD 57101) offering a 'simplicity design' **polar mount** that arrives to dealer assembled as a guide to how the unit is supposed to look when installed. They do recommend that you dis-assemble it before installation because of weight. Design is unique to company.

Receivers

Earth Terminals (513/489-6300; One Microwave Plaza, Cincinnati, Oh 45242) has added **tunable audio** to their satellite receiver. Unit is a factory retrofit, tunes 5.5 to 8.5 MHz, and may be added to 'black faced models' only. Retail price is \$100 for retrofit. Also available, special fixed-tuned audio subcarrier boards for specific audio channels between 5.5 and 8.5 MHz, as replacements for standard 6.2 and 6.8 (front panel selectable) audio subcarrier frequencies.

ICM Video (405/232-5808; P.O. Box 26330, Oklahoma City, Ok. 73126) announces new **commercial grade TVRO receiver**; model SR-4400-B. Unit is dual conversion, separate down converter, tunable audio, detent tuning, signal level meter, polarization driver and selector, 30 MHz IF bandwidth, PLL video detector, automatic frequency control, automatic gain control. Retail price is \$1065. Contact Mike Janko.

Regency Electronics (317/545-4281; 7707 Records St., Indianapolis, In. 46226) announces new **single conversion TVRO receiver**; model SR 3000. Unit has separate down converter, detent tuning with automatic frequency control, polarotor control, preset plus variable audio subcarrier tuning, signal strength and center-tuning meters and audio plus video 'fine tuning' controls. Retail price is \$549.94. Contact Marc Diebold.

Satellite America (601/227-1160; P.O. Box 552, Grenada, Ms. 38901) announces new model SA-2000 **TVRO receiver with infrared remote control**. Unit has LED transponder selection, full matrix or stereo audio. Contact Christy Fowler.

SERVICES

International Video Communications (214/247-1006; Suite 105, 2081 Hutton Drive, Carrolltown, Tx. 75006) has been selected as the 'video arm' of the **World Satellite Network**. WSN hopes to link up churches worldwide through satellite inter-linking and will conduct a live satellite inter-connection of as many as 5,000 churches September 16-17-18 from Houston, Texas.

AT DEADLINE: 11th Hour Reports

NASDA/ the Salt Lake City based satellite dealer's association, attempting to get off the ground since last spring, has called it quits. Group had planned a very ambitious program of insurance, sales aids, 24 consumer TVRO 'shows' per year and a host of products and services for dealers. Those who 'paid in' will get their money back according to NASDA spokesman.

SHOW NEWS: Sat-Expo San Jose (Oct. 9-11) called off; lack of support. **STTI Nashville** opened 40,000 square feet new exhibit space, promises 300 booths Labor Day weekend. **SPACE Las Vegas** still hanging fire. **STTI Las Vegas** claims 78% (+) booths pre-ordered. **NCSA Denver** (15-17) getting big dose of 12 GHz romancing from early DBS programmers. **PRICES:** CJR survey found virtually unanimous agreement; June and July dead-even months with level, steady dealer business. **Look for slow increases** in TVRO hardware prices through fall, however. **HARDWARE:** Splash plate feeds on way out, quickly. Prime focus .3 'in.'

NOTICE TO READERS:

CJR is provided without charge to **Dealer Members of SPACE**, the national trade association for the home TVRO industry in the United States. **CJR** is published as a mid-month companion to **CSD** (Coop's Satellite Digest) and is available to all other dealers and distributors for a nominal annual subscription fee (see page one, here; bottom of page).

Original Equipment Manufacturers (OEMs) are encouraged to submit new product releases for inclusion here in **CJR** to both of the following **CJR** editorial offices: **Carol Graba**, CJR, P.O. Box 100858, Fort Lauderdale, Fl 33310, and **Larry James**, CJR, P.O. Box D, Claremore, Oklahoma 74017.

MARKETING: UNIVERSITY- COLLEGE SYSTEMS

ON The Ground Floor

One of the vast, undeveloped markets for TVROs is the University/College/Junior College system in America. If there ever was a marriage 'made in heaven', it is the combining of low-cost (home) TVRO type technology, and, the nation's learning centers. To date, however, only a handful of the nation's Centers Of Higher Education have discovered TVROs and what they can do for the campus program. We hope this will give you some insight into the type of market that exists here, and lead you to your local campus to talk with the people there.

If there is ultimately a 'father of campus TVROs' named, it will undoubtedly be a man named **Lee Lubbers**, a professional educator at **Creighton University** in Omaha, Nebraska (**Lee Lubbers, Creighton University, California at 24th St., Omaha, Nb. 68178; 402/280-4063**). Lee first became intrigued with satellite communications, and satellite television reception in particular, by stumbling across some articles written by Coop in the general press. Gambling some of the University's money, he ordered a set of Coop manuals from STTI and began to dig into the hardware problems. From there he was led to **CSD** and eventually to David Johnson or Paradigm Mfg. Co. Johnson arranged for some equipment for Creighton University and today the Creighton University TVRO system is one of the most unique and innovative in the world.

Appearing on **Sat Scene Magazine** in an interview taped at CAN-AM '83 in Minneapolis last June, Lee explained how the system worked. One antenna is dedicated to the Russian Molniya satellite. That's that strange satellite system that operates by swinging far to the north of the equator and turning in a loop high over Central Canada. Using this 'over-Hudson-Bay' transmission point, the Russian Molniya birds (there are four operating, spaced approximately 6 hours apart) **look back down over the top of the North Pole** into those sections of Russia (such as Siberia) which are too far north to have a decent look at the geo-stationary/Clarke orbit belt.

The Creighton system was created by the students, and instructors. A desk top computer has been programmed so that the 'path' or 'pattern' of the Molniya satellite is inside the computer's memory. This computer memory drives the dish using a combination mount; one that has both azimuth (left/right) and elevation (up and down) tracking drives. The computer knows where the bird will be in its 'loop-the-loop' flight path over northern Canada, and it tells the dish where to point, and when. In this way the dish is always bore sighted on the slow moving bird and the people who use the system's programs are free to concentrate on the program content and to simply forget about the fact that the bird is not geo-stationary in space (i.e. in one spot all of the time).

Creighton University has an MATV (master antenna television) distribution system that inter-connects the classroom facilities as well as many of the student dorms. Into this system are plugged several 'satellite channels'. Unlike the normal HBO/WTBS/ESPN program distribution format, however, this system specializes in carrying things like the Russian Molniya broadcasts; SPN's TeleFrance, Mexico City's XEW and other non-USA programming. Lubbers on why this makes sense.

"Television has always been a great entertainer. It has also been a mediocre teacher. On occasion, it is also a good informer. We are simply concentrating on the **informational aspect** of the television service. We have found tremendous interest from our language department. When they found out that they could have real-world French or Spanish or Italian or Russian television in their classrooms, the teachers developed an entire new thought process about teaching foreign languages. Until that time the teacher had been the primary source of the language being taught. The teacher may be good, but he or she is not perfect and other than cassette tapes that lack the immediacy of the real world, the students have been forced to learn a foreign language that comes only from the teacher's mouth."

Having access to the foreign language programming has, according to Lubbers, changed many of the attitudes of students. Foreign language studies have changed from dry, monologues, to real-world, live, events. Since the various foreign language telecasts are available not only through the campus MATV system in the classrooms, but also in the dorms, the students can take their language studies 'home with them' to the dorms. A typical homework assignment? "Watch the 'Good Morning Siberia' newscast on Molniya and be prepared to discuss, in Russian, the content of the newscast".

Lubbers has done more than simply pioneer the use of satellite services at Creighton (a co-ed school founded in 1878). Inspired by the reaction of his own University professionals, and the intense interest shown by the students, Lee Lubbers has become a one man, world-wide advocate of an international consortium of institutions of higher education using satellite communications on a regular basis.

First Lee put together a three day Conference, at Creighton, this past May 19-21. More than 50 (very) interested educators attended and paid a fee to Creighton. They came to learn about how Creighton has pioneered use of TVROs, and to see if they might get similar activities started at home.

Robert E. Thompson from the La Crosse facility of the University of Wisconsin: "... **The conference was a success beyond our wildest dreams.** (In my case) ... it seems possible that departmental funds might be found for hardware, which would bypass the 'grant proposal technique'. I have been encouraged (by university funding people) to request the money outright".

Lubbers and others who attended felt that the Creighton system really opened the eyes of those educators attending; they almost had to 'see' and 'touch' the working system to appreciate how many educational benefits were there. And in terms of university funding programs, the money required to install a modest 'starter' TVRO system might not be as big a problem as some had suspected. Most university campus areas now have at least a start on an MATV system, a point Lubbers feels was key to the widespread acceptance of the service at Creighton.

"**Had we been constrained to show off the various services** possible on a group of monitors in a classroom or two, the project may have died before it began. But because we had an operating MATV system, we were able to plug in on some new channels and instantly we had campus wide coverage. People on the staff who showed no interest in the project initially suddenly became intensely interested when they discovered the programming on their TV dial".

Successful in inspiring other educators (they promptly formed an association, known as SCOLA which stands for **Satellite COmmunications [for] LeArning Worldwide**), Lubbers then set his mind and volunteer staff busy surveying where the presently available satellite programming services on domestic satellites were missing some of the major 'language events' in the world. German jumped up and bit him. There was no regular German television available. Lubbers decided to find out why and this trail led him to **Zweites Deutsches Fernsehen (ZDF for short)**, a major German television network. ZDF has now agreed to provide a one hour minimum videotape dub of ZDF programming to SCOLA each week, taken directly off of German television. That was obviously a start, but what do you do with the tape? Bicycle it around? That seemed very old fashioned to Lubbers.

"**Meeting with the German Consul in Chicago**, we began to explore how some of the major German companies might be 'sold' on paying the costs associated with taking the ZDF delivered tape and purchasing US domestic transponder time to uplink it through SAT-

COM or WESTAR for simultaneous use all over the USA". In case you haven't figured it out yet, **there are certain things educators can do which the normal person cannot do.**

Off and running with the start of some German television programming. Lubbers is now concentrating on other 'missing' languages. Scandinavian, Arabic, Japanese, Chinese head the list. And since the Russian Molniya satellite requires its own dedicated terminal (something many of the Universities may not opt to do, initially), Lubbers is exploring taking Molniya reception and recording it for later relay nationwide on a domestic satellite.

To help fund this, on a worldwide basis (Lubbers and his fellow educators see an eventual worldwide network of centers of learning, all inter-connected via satellite), and to get the whole project out of the nickle and dime funding league, Lubbers is putting the finishing touches on an application for an 'Annenberg Grant'. This is a very special dollar-grant program established years ago by the Annenberg Foundation, and the purpose of the grant is to help fund new and creative concepts in educational communications.

One of the areas quickly identified by Lubbers as an impediment to the natural growth of satellite communications technology, and its use for learning worldwide, is the **present** Intelsat system. Out of initial ignorance, the group approached Intelsat for quotes on delivering to the USA live German (etc.) television programming. The costs were 'astronomical'; far more than even an 'Annenberg Grant' could handle. This piqued Lubber's interest in **why** the Intelsat rates '**are what they are**', and more importantly, '**why they HAVE to be that way**'. Turning a group of inspired educators loose on Intelsat may ultimately be very productive for the whole of the satellite industry. Remember, '... there are certain things an educator can do which the normal person cannot do ...'.

Now, how does all of this interest **you** as a **TVRO dealer**? In many, many ways. Or at least it should.

First of all, **you have a product to sell** to the Universities, and colleges and Junior Colleges in the United States (plus Canada). But **you are not** an educator, and you need some help in learning the educator's interest area. If you can interest an educator, and demonstrate what you have to sell, you will sell him. You also need some 'insider information' relating to the ways that educators are able to get funding for 'pet projects'; it won't do much good to inspire your local university types if you leave them salivating, but too poor to respond. That's where another professional educator can help. And his name (no surprise here) is Lee Lubbers.

Lubbers is very willing to help you explain to your own college or university just what this type of system offers to them. Because he is at their level, they will accord him certain courtesies that you will not get until you earn their respect. Lubbers makes it very easy for you to call upon him for help; Creighton maintains a toll free 800 number (800-228-2700) which you can use to get yourself acquainted with this innovator in campus satellite systems.

So start by calling Lubbers and getting acquainted. He'll help you through the 'language' of educators, and he may even end up suggesting that you be prepared to 'donate' some of your time, services and perhaps even some equipment to get the project going. Don't be afraid of that one . . . you will be amply rewarded down the road for helping your local educational center get started on this path.

Then, it just so happens that the next SCOLA Conference will not be held until May 21-25 in 1984. That gives you many months time to acquaint yourself with the local educators, to work back and forth with Lubbers in better understanding what SCOLA can do for the local university and college campuses, **and to prepare to attend** the May 84 conference in Omaha **along with** your local educators.

Remember that one of the key elements in making the system work for the campus is to have the satellite delivered services universally available in as many places as possible. Where they are no existing MATV systems, or where the systems were designed with different purposes in mind, you are looking at a contract for **not only** a couple of satellite dishes, but also for providing a complete and often extensive MATV system. If that scares you, **CJR** will be working with SCOLA to provide some excellent training in this area **before** you really need it.

There is one more, parting, aspect to the SCOLA initiative which

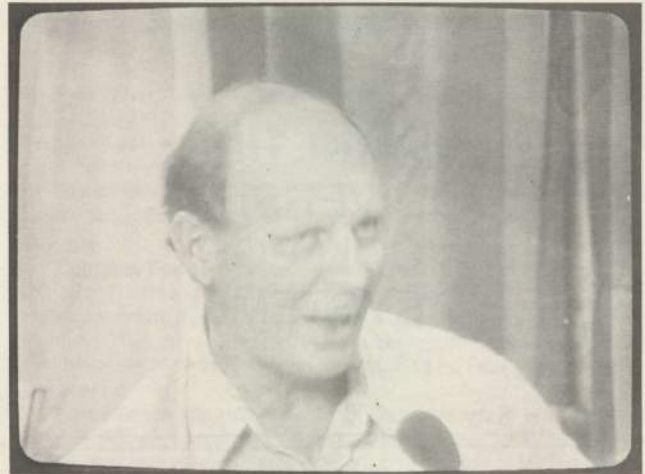

LEE LUBBERS on Sat Scene Magazine, during August, talks with Coop about the SCOLA project.

deserves some recognition. Each campus system is going to reach hundreds if indeed not thousands of impressionable, enthusiastic, students. These students will be exposed, for the first time in most cases, to the potential of having a TVRO. Many will take that message 'home', and if they benefit and enjoy the systems piped into their class rooms and dorms at school, they will be anxious to have a similar system at home. **Some** of their parents will be able to afford such a system, and **some of those** will be potential customers for you. Like many small acorns, from this project many-many large 'oak trees' can grow!

CALENDAR/ Through October 1st

AUG 22/24: SCUC'83 (Fifth Annual Satellite User's Conference), St. Louis. More than 250 exhibits, 3500 attendees predicted. Contact 303/694-1522. (****)

SEP. 5/7: SIBCO'83 (Second Annual Conference), Nashville. More than 300 exhibits predicted. Contact 800-654-9276. (**)

SPE12/13: DBS III: Third Annual Conference on Direct Broadcast Satellites, Washington, DC. No exhibits; lectures. Contact 301-989-0666. (***)

SEP 12/14: CAST '83 (International Cable and Satellite Television Exhibition), Birmingham, England. Contact 01-487-4397 in London. (**)

SEP 15: 'Buying Your Own Earth Station; Making The Right Decision' (one day conference (no exhibits) for those involved in installation and use of TVROs for semi commercial and commercial installations); Washington, DC Contact 202/331-1154. (***)

SEP 19/20: Space Systems 2001 (symposium to assess Defense Department's future space system needs; also to be carried via satellite (bird not known) to Los Angeles and Dallas. Contact 202/638-7430. (***)

MOVES/Through October 1st

Aug 15 (approx)/SIN and Galavision to move from F4 to G1.

NEW BIRDS/ Through October 1st

RCA F2R scheduled to begin tests at 72 west around September 10.

AT&T TeleStar 1 scheduled to begin tests at either 76W or 96W around September 15.

Explanation of rating systems:

- * — Event not recommended.
- ** — Marginal event with one or more serious flaws.
- *** — Good event, recommended if topic matter is of interest to you.
- **** — Superior event, recommended if you have interest in any thing relating to satellites.

EARTH STATION RECEIVER



ESR224 RECEIVER

FULL PERFORMANCE SATELLITE TV RECEPTION

- All 24 Satellite Channels • Attractive Styling
- Detent Channel Tuning • Normal/Inverted Video Switching
- Variable Audio Tuning for All Subcarriers
- Channel "Scan" Function • FCC Approved Modulator Available
- Polarotor™ Interface Standard • Optional RT224 Remote Control Available
- Matching Stereo Adaptor Available

*Polarotor™ is a registered trademark of Chaparral Communications Inc.

Write for Brochure or See Your Dealer



R.L. Drake Company
540 Richard St., Miamisburg, Ohio 45342, U.S.A.
Phone: (513) 866-2421
Telex: 288-017

ENGINEER MEMBER OF
SPACE

INSIDER: ONE MANUFACTURER'S VIEW

Introduction-

The TVRO dealer, functioning as the last 'link' in the distribution 'chain' makes the assumption that he and only he is on a fast learning curve; that others, such as the distributors or original equipment manufacturers (OEMs) are far ahead of him in detailed planning and careful study. That may not be the case.

Dealers are placed in a position of 'relying' on what they are told by the people they purchase from. They 'trust' the distributor or the manufacturer's sales rep to give them the data they need to make intelligent buying decisions. This month's 'Insider' look suggests that in some cases that 'trust' may be mis-placed.

Our attempt here is not to discredit any single manufacturer, nor any group of manufacturers. Rather, we simply want the dealer to learn that perhaps he should **question**, in depth, those from whom he purchases, more often. They may think they know the answers because someone has told them certain 'facts'. If you, the dealer, accept those statements as fact, and then make certain business plans based upon those 'facts', you could well regret such decisions at a later date.

The following is a transcription of a multi-way conversation held a few months back at an industry event. The entire conversation was videotaped, with the knowledge of the participants, but was later found too explosive for use on **Sat-Scene** magazine. By eliminating the names of those participating, and by eliminating the direct references to the company being discussed by the group, we hope you will concentrate on **what was said** and ignore who might have been saying it, or about whom they were talking.

Setting The Scene-

There are two primary conversants in the group. One is a dealer operating in the Rocky Mountain States. He specializes in semi-pro installations for oil rigs and other remote sites. The second is a leading manufacturer of TVRO hardware; one of the fellows who builds TVRO receivers under contract for a wide variety of the 'marketing types' in the industry today. Others in and out of the conversation include an engineer to two.

Dealer: Why doesn't Company X build their own TVRO gear?

OEM: The 4 GHz stuff for them is nothing more than a stepping stone to establishing a marketing program for 12 GHz. They don't expect to make any money at 4 GHz and they don't even like 4 GHz!

Dealer: They don't seem to have the smartest people working with their 4 GHz systems . . .

Engineer: Don't kid yourself. They have an excellent line of hardware in many fields . . .

Dealer: OK, look at their antennas and . . .

Engineer: The antennas are made by (name of company); a well respected name in antennas.

Dealer: I was going to say . . . and their mounts. It is a very poor mount. If you had unlimited time and lots of guys to help, it wouldn't make any difference. But when you are on top of a mountain in Wyoming and the temperature is 40 below zero with the wind chill factor, that mount is a man killer. And I don't think that is very

smart! They are terribly dis-organized. Oh, have you seen this brochure describing their new consumer receiver (pulling brochure out of folder)?

OEM: Let me see that . . .

Dealer: Doesn't **your company** manufacture that receiver?

OEM: (glancing through four page brochure) . . . Yes, we do.

Dealer: Then maybe you can help me understand some of the statements in the brochure.

OEM: Well, just for openers, the receiver doesn't look like this picture.

How much are they charging for this receiver?

Dealer: The price is \$425 at the distributor level.

OEM: How did you **know** this was a receiver we are manufacturing?

Dealer: Word gets around . . .

OEM: Who told you?

Dealer: Can't remember. I know that (name of company) didn't tell me. I wanted to get some of the down converters to test; we need some multiple receiver packages for some jobs I am bidding.

OEM: Multiple receiver packages? You mean double conversion receivers?

Dealer: Yes . . .

OEM: They told you **this** was a double conversion receiver?

Dealer: Yes!

OEM: Well guess what; this is a **single conversion** receiver!

Dealer: But they told me it was double conversion. Look, here, in the brochure. See what they say? Double conversion.

OEM: I can't believe this. I have never seen this brochure before. They created all of these specs on their own. We haven't even given them **our** specs yet. **They made up all of this** just to print this brochure!

Dealer: So it is NOT double conversion?

OEM: No.

Dealer: I can't believe this; right here in the specifications, it says dual conversion. And that's what their sales rep told me. When I mentioned I was starting to do some multiple receiver installations, he said this was just the unit for me. He drew me a diagram of how I could stack these receivers **without isolators**; he called it a 'price breakthrough' in low-cost receivers; double conversion for the price of single conversion.

OEM: (Smiling) How would YOU like to work with these guys!

Dealer: Well, I've dealt with several different guys. You can tell by the answers they give to questions just how much they know; or don't know, as is usually the case.

OEM: I need to qualify my statements. This is a brand new product. Until **we** have it totally out of engineering and into its final production form, **we** are not about to give **them** a full set of specs. If we tell them too much too soon, they do something crazy like print up a four page brochure! That reduces our opportunity to do innovative design things right up to the end. When you tell them the unit will have a certain noise figure, or whatever, that kind of freezes that spec right there. And then we have to go back to them and wait for them to approve the change.

Dealer: So they didn't know it was **not** going to be double conversion?

OEM: Oh no, that was frozen from the start. It was **always** going to be single conversion receiver!

Dealer: OK, and then they call me up and get me all excited about this brand new unit and it sounds like everything I ever wanted at a tremendous price . . . ahh, does it have stereo in it? I hate to point it out, but here in the brochure . . .

OEM: It has stereo. That was frozen in from the beginning also.

Dealer: I was actually afraid to ask, after the double conversion . . .

OEM: Many of the changes are minimal, things that I would know because **we** designed the unit. Look at the photo here in the brochure . . . see that row of LEDs? They aren't in the unit. This center tune meter? Not there . . . these knobs they have on the front panel have just been glued on the panel. The guy who put this mock up together never talked with us; he just laid it out on a case and put the knobs and LEDs where he thought they looked good. Any resemblance to the real product is a coincidence.

Dealer: Good grief. It all looks so finished, so complete. This brochure had to cost them thousands of dollars. They even invited me to (name of city) to see a **working model** of the unit, a special



'advanced showing', last week.
OEM: They had it there. We gave them **one** pre-production, lab sample. They are hauling the only one they have all over the country showing it off in special, advanced showings. We are handing them over a second, 'real' receiver, today.
Dealer: Yeh; now they can do 'advanced showings' at **two** cities in the same day since they have two receivers to their inventory. Wow.
OEM: Look, these guys that you deal with, the guys I deal with . . . they are under intense corporate pressure. The guys that cranked out this brochure were undoubtedly pushed into getting a brochure out the door by people higher up. Everyone is in a big hurry, and they come to a firm like us and expect miracles overnight.
Dealer: When they first told me about the unit, before I got this brochure, they said I could have my first shipment two weeks ago today. I didn't order any of the first batch . . .
OEM: It is still going to be a while. They are in a very tough spot, one they made for themselves. They expect to have a new product designed for them, from the ground up, in just six weeks time. From original concept to first shipments of a finished product in six weeks. If you tell them that you will have a (brand new) artwork design and **possibly** the first (circuit) board in three to four weeks, they go back to corporate headquarters and interpret this to mean **three weeks**. Then on top of that, nobody at corporate understands what a board-artwork is. **They think** that is a complete pre-production receiver, built and de-bugged and aligned. Based upon this erroneous assumption, they start all sorts of marketing and promotional types moving with their own support products. A brochure like this is a perfect example of what happens because one person mis-interprets what he has been told.
Dealer: The problems are not just at the top. They have the whole nation divided up into sales office districts. Look here in the brochure . . . a whole set of different offices covering different parts of the country. You call these guys, **any** of these guys, in or out of

your district, on the telephone for information and you know what you get? An answering service.
OEM: Remember what I said? 12 GHz. This whole thing is nothing but a test for 12 GHz, a fire drill.
Dealer: Well, it isn't working. The whole outfit is dis-organized!
OEM: They think it's working. When or if they really want into the 4 GHz market, they'll move on us. But their whole vision is on 12 GHz. Right now, 4 GHz is just a training exercise. When 12 comes along and it gets serious, they will pop in with top to bottom professionals. Right now they are running loose and sloppy and that lets the crud settle to the bottom and if there is any 'cream' in the pot in the way of professional people on board, they will rise to the top. The money they are losing right now is nothing; not when it is compared to the money up ahead on 12 GHz. They can afford to make a lot of mistakes along the way because when they finally have it together and right, then the big bucks will be there.
Dealer: I hear you, and it will be interesting to see what happens to the 'little guys' when all of this happens.
OEM: They expect them to fade away, quit, or stand by to be gobbled up . . .
Engineer: Don't be so sure about that.
Dealer: At 12 GHz, will they need 'little guys' like me; dealers who have developed a working knowledge of 4 GHz terminals and terminal basics?
Engineer: They'll do whatever their marketing plan tells them to do. But I wouldn't count on being a part of what they are planning, at 12.
OEM: Frankly, they don't know yet. That's what the 4 GHz training exercise is really all about. They are collecting data and testing their own systems and personnel. When the time is right, they'll review everything that has happened and everything they have learned, and then make a decision based upon the facts and circumstances at that time.

IF YOU ARE A TVRO DEALER/ A TVRO DISTRIBUTOR/ A TVRO MANUFACTURER . . .

CJR is NOT for everyone. It is the mid-month (AIRmailed the 15th of each month) dealer/distributor newsletter strictly for TVRO equipment suppliers. **CJR** provides the perfect 'mid-month-filler' between **CSD** and other publications which are mailed to you on the first of each month. **PLUS** — CJR turns around from final 'copy' to the U.S. postal system in just three days time; that's fast! **AND** — that guarantees you the latest news, marketing trends, pricing conditions, and product news (plus a feature or two each issue) fast enough that you'll have it in your hands soon enough to really **PROFIT** from the information.

_____ **ENCLOSED my check for \$35** for a 12 month subscription to **CJR**. I reside within the USA or where US 'zip codes' apply. **Oh Yes**, attached is my business card/letter head as **proof** that I am in the equipment business and that I qualify for a subscription.

_____ **ENCLOSED is my check in US funds for \$45** for a 12 month subscription to **CJR**. I reside **OUTside** of the USA/U.S. zip code area. Attached is my business card/letter head as proof that I am in the equipment business and that I qualify for a subscription.

NAME _____

NAME OF COMPANY _____

Address _____

Town/City _____ State _____ Zip _____ Country _____

Send subscription, payment to:
CJR/Cooper James Report
 P.O. Box 100858
 Fort Lauderdale, FL 33310

SERVICE: WHERE TO START WHEN IT BREAKS

WHERE To Start?

"My system has quit". Not a pleasant message. You had better things to do today than run 45 miles out in the country to see what could have happened to Farmer Brown's TVRO. You are particularly nervous because this is a new brand of system to you, and your own experience with equipment is not that solid yet. Maybe you will get lucky and find a blown fuse!

Until a dealer has worked again and again with a particular system lash-up, and experienced system problems (and solved those problems) there is always the fear of the 'unknown'. What extra-special 'twist' has **this** manufacturer built into his system? What do you mean they don't have a fuse between the receiver and the LNA!

A total system failure should always begin analysis at the powering end of the system. This strongly suggests that power to some or all of the system has quit. Perhaps the power quit because a fuse 'did blow'. Or, perhaps the power is present to operate part of the system, but not the balance. Let's start at the top.

- 1) **Power.** All TVRO systems plug into a standard 110/120 volt AC (VAC) outlet. That's common household current. But none of the system (the receiver/demodulator proper, the down converter, or the LNA) actually operate on 110 VAC; they operate on some far lower, DC (direct current) voltage. Most of the voltages that you will be looking for, or measuring, are in the 12 to 25 volt region. And that's DC; just like you get from a car battery.
- 2) **Inside** of the receiver is a 'power supply'. The power supply has a relatively simple chore; it takes in the 110/120 VAC and it turns that alternating current source into a direct current source. And because the TVRO electronics don't require such a high voltage (such as 110/120 volts), the power supply also lowers or reduces the 'supply voltage' to a lower level.
- 3) **Most** TVRO receivers contain a pair of fuses; devices that 'blow' or quit when some predetermined 'unsafe amount of current' passes through them. The first fuse (often 1/4 to 1 amp) is on the 110/120 VAC line. It is actually part of the AC plug circuit, usually connected in one side of the AC plug line and separated from the line by the power on and off switch that is the master power switch for the receiver. The second fuse is located on the 'DC' or operating voltage side of the power supply. It is typically in the plus or positive side of the DC supply, just after the supply proper and before all of the equipment that feeds off of the supply.
- 4) There is another approach to 'protecting' the power supply. The fuse is really a protection device; it is rated at some 'safe current' value (such as 1/2 amp) because that is a 'safe margin' above the normal operating current of the DC supply. You can visualize the DC power (12 to 25 volts typically) as a water supply. When too much water flows through the pipe (electrical current flows through the wire), an automatic valve (the fuse) stops the flow of water (electricity). The receiver designer knows exactly how much current will be used from the power supply to operate the receiver, the down converter and the

TYPICAL TVRO RECEIVER POWERING

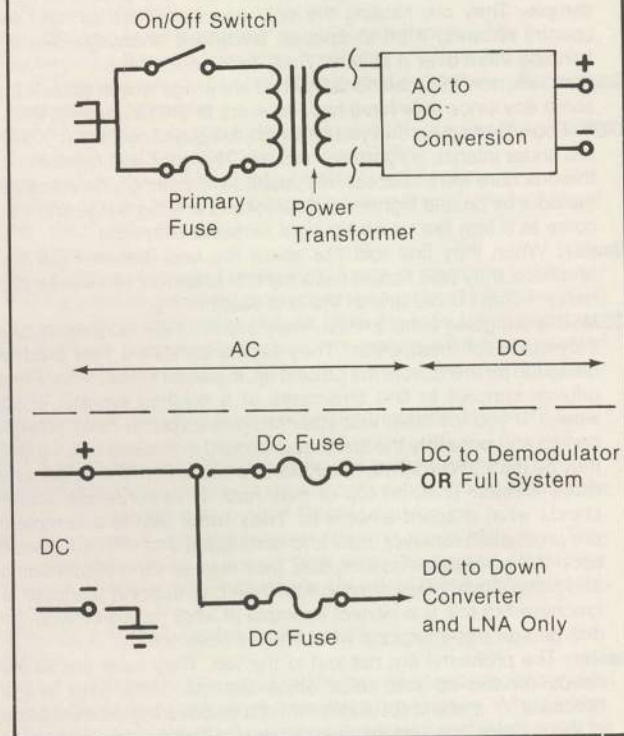

LNA. He adds to this known amount (measured in amps or parts of an amp called milliamps) some 'safety factor' to handle brief overloads. Then he selects a fuse that is equal to that amount of 'safe current'. Any more current than that flowing through the circuit/system, and the fuse heats up and 'snaps'. That's not a nuisance; that's to keep your system from developing a fault (i.e. short), and taking so much current out of the power supply that the power supply literally goes up in a puff of smoke. Better to lose a fuse than the whole power supply (or receiver).

As noted, there may be a fuse in the 110/120 VAC 'primary' side of the receiver, to protect the receiver from overloads; there may be a fuse in the 12-25 VDC side to protect the power supply proper. And, there could be a fuse in the line that carries power out of the receiver/demodulator proper, outdoors, to the down converter and the LNA. The two fuses (if there are two) may look identical, but chances are they are not rated the same. The primary side fuse, the one that goes into the 110/120 VAC line, is going to have a larger current rating (i.e. carry a bigger load) than the fuse in the DC (secondary) side of the line. Why is this so?

All of the current for the full receiver, the sum of the demodulator, the down converter, the LNA and the dial lights and fancy do-dads, **goes through the primary side fuse.** On the other hand, the fuse on the secondary side may only protect the portion of the DC supply that goes outdoors to the down converter and LNA. Thus you may find a '1 amp' fuse on the primary side, and a '1/4th amp' fuse on the secondary side. Don't be tempted to 'elevate' the value of the secondary side fuse.

OK, so you didn't have an 'exact replacement' 1/4th amp fuse handy and you stuck in what you did have handy. 1 Amp. Now, what might happen to you having done this terrible deed?

First of all, you cannot be sure why the fuse went south in the first place. It could blow because the fuse was defective. That doesn't happen often, but it does happen. Maybe the 1/4th amp fuse was really a 3/16th amp fuse and it got mis-marked or was defective in manufacture. That could cause it to blow when nothing was wrong.

Channel Master®...



IT'S EASIER FOR YOU TO SELL TO PEOPLE THAT KNOW US.

They're the people in suburban and rural markets that already depend on Channel Master high-gain TV antennas and amplifiers for the best reception that they can get. When you offer Channel Master earth stations to your prospects, the chances are very good that they've heard of us and our reputation for high-quality reception.

They're the people in over 8 million American homes with a Channel Master antenna rotor control box in their living room. They're some of the users of the 21 million Channel Master outdoor TV antennas sold over the last 34 years. **Some of our competitor's names may be well known to us in the satellite "trade" but to the average consumer they mean absolutely nothing.**

Over the past 34 years, the Channel Master name has become synonymous with superior TV reception, recognized again and again by leading consumer testing magazines. You clearly benefit from this reputation, as well as by having a single, brand-recognized name to sell...not separate names for the dish, receiver, LNA, polarizer, dish controller and stereo processor. And not separate guarantees or service centers, either.

Check it out. And let our Distributors show you satellite TV the way it's supposed to be. They're ready with inventory and technical assistance to make your life easier in this hectic new industry.

Channel Master....dedicated to better reception since 1949.

 **CHANNEL MASTER**
SATELLITE RECEPTION EQUIPMENT
DIVISION OF AVNET, INC., ELLENVILLE, N.Y. 12428



We need new dealers and distributors for selected markets who can specialize in this new and growing industry. Please write or call Don Berg or Phyllis Fisher for immediate consideration. (914) 647-5000.



Or, maybe the fuse was a 1/4th amp fuse but nothing was really wrong. It blew because of a sudden 'voltage spike' or 'transient' on the AC side of the line, and that extra amount of voltage on the primary side caused the DC supply to put out a sudden increased amount of voltage on the secondary side. The fuse 'blew' because that is its job when something like that happens.

Or, most likely of all, the fuse blew because something in the down converter / LNA side of the line **was drawing too much current**. More than 1/4th amp of current to be exact. Now, what happens when you 'substitute' a 1 amp fuse for the factory recommended 1/4th amp fuse?

Somebody sat down, when they designed the receiver, and they selected parts for the power supply and the down converter based upon the assumption that no more than 1/4th amp of direct current was ever going to pass through those parts. Now you come along and upgrade the fuse to 1 amp. If some part in the system has gone bad (or if you got some moisture inside of the coax going to your LNA, from your down converter, for example), and you now allow the system to draw 1 amp of current before the fuse (protection) blows, you have just exposed all sorts of parts to 4 times as much current as they were safely rated to handle.

The first thing you are likely to do with such a fuse substitution is 'melt' some part inside of the down converter; if there is a real 'short' on the line someplace. Meanwhile, as this is happening out at the down converter, the AC to DC power supply is sitting there grunting and groaning trying to supply the extra current; more current than it was designed to handle. Some of the power supply parts now get very warm, and one or more of them 'snap'. **Now you have two problems**; the original problem out on the line that caused the normal 1/4th amp fuse to blow, and a busted power supply section that **you blew up** by allowing the 'safety fuse' to be bypassed for a higher value fuse.

All of this can, and does happen, because when some section of a receiver/down converter/LNA develops a 'short' (taken to mean that a part has failed, and 'fused'/'shorted' itself to 'ground'), the capacity of the short is almost infinite. It can 'short circuit to ground' almost any amount of current you can supply to it. Stick a ten amp fuse in the line, in place of the recommended 1/4th amp fuse, and you'll get ten amps going directly to ground; for as long as the power supply can put out such a nasty amount of current.

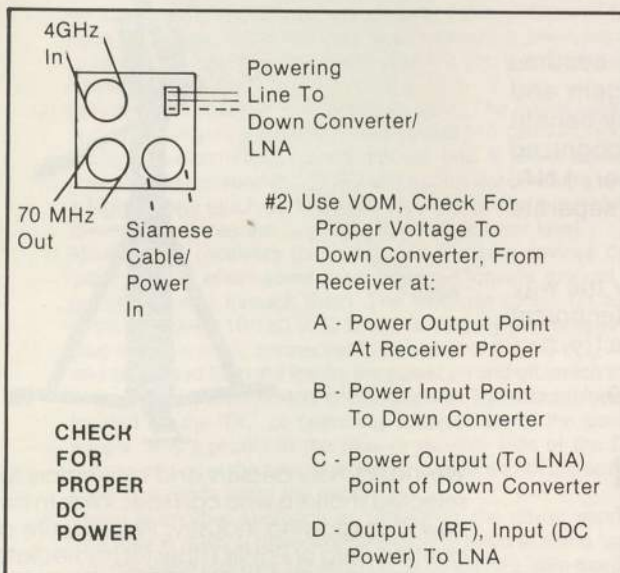

So here you are wondering where to start. First of all, check to see whether we have power where we should have power. The primary side? The fuse should be good and the demodulator will probably indicate it is functioning (lights will glow, meters will move). The secondary side? That's a little tougher.

Receivers have to get power to the down converter/LNA some-

how. They may elect to send the DC operating voltage/power out to the down converter and LNA through the same coaxial cable that connects the down converter to the demodulator. Or, they may send it through a number of extra, secondary (small) wires. Or again, they may send it through a second piece of coaxial cable (so-called Siamese cable because the regular TV signal coax and the power carrying coax are physically joined together in a single outer jacket). In any event, you start by finding how the power gets to the down converter and LNA.

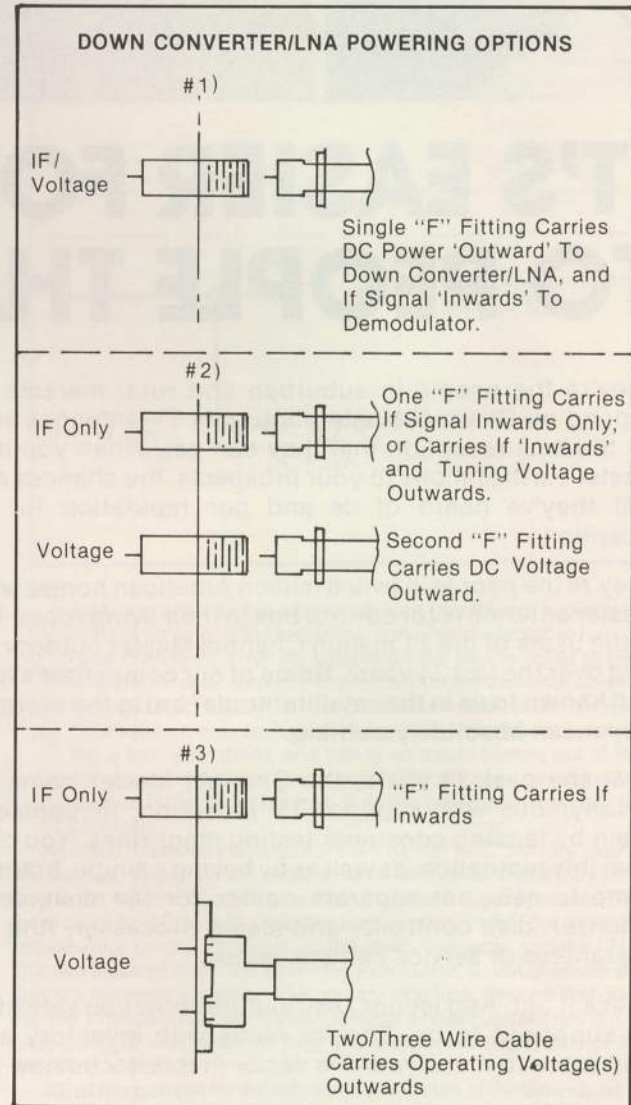

Then test (using a suitable DC meter) whether the proper voltage is at the receiver/demodulator jack. A typical value will be in the 12 (rare)/15 to 25 volt (DC) region. Make sure the meter you are using is in the DC voltage position and touch the black lead of the meter (ground side) to the chassis (metal) ground of the receiver. Touch the red lead of the meter to the positive connection on the receiver. This may be a terminal strip screw marked "+ 24 VDC" or it may be an (F style) chassis mounted coaxial cable fitting (in which case the center pin on the connector is the one that carries the DC voltage).

Voltage OK there? Reconnect everything back up and we'll go outside to see where the problem is? Ooops. You say there is no sign of a positive voltage going to the down converter and LNA? Time to take the top off of the receiver to look for the DC side fuse. Or maybe the manufacturer put it on the back apron of the receiver, along with

the primary side fuse.

If we are to the fuse **changing spot, don't substitute**. That's why you always check your tool kit before you leave the shop; make sure you have a full set of the **proper value fuses** on hand!

Moving outside, logic tells us that if we had power coming out of the receiver and heading for the down converter, we should be able to take our test meter and check for the same voltage (or a very slightly lower voltage) where that same cable plugs into the down converter. Check there first.

No voltage? Check again. The only thing between that check point and the demodulator, where you had voltage, is cable. If you lost it **between** the two points, the problem is **in the cable**.

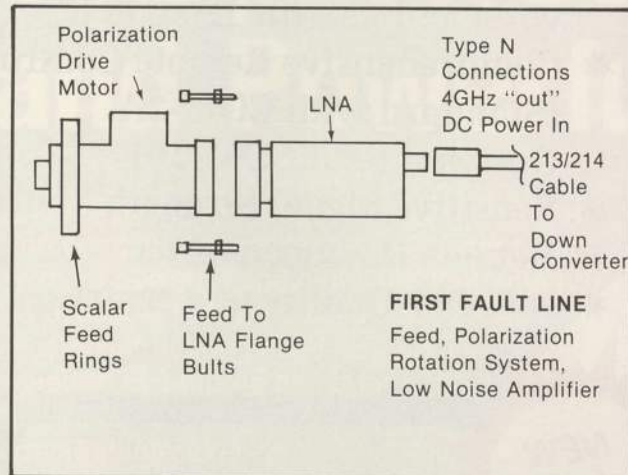

If we have voltage to the down converter, we should now unscrew the RG-213/214 N type connector that connects the **input of the down converter to the LNA**. This assumes you are 'cable powering' the LNA, through the 213/214 cable. Now be very careful. Attach the black/negative lead of the DC voltage meter to the ground side of the down converter. That's any metal part of the outside of the chassis. Now the careful part. The red probe, just the metal tip, should very carefully touch the **center pin** on the chassis mounted type N connector on the down converter. And you should read a voltage here.

The voltage to the down converter powers the down converter. It **also goes through** the down converter and flows **into the LNA** to power it. If the down converter has had a powering problem, internally, you may have voltage **to** the down converter but **no voltage passes through** the down converter to the LNA. An LNA without voltage will not work!

If the down converter had voltage, but the input to the down converter, where power comes 'out' to power the LNA, has no voltage, your problem could be one of two places:

- 1) Inside of the down converter a part has 'snapped'; or,
- 2) Some clever engineer has placed a **separate fuse** inside of the down converter to protect just the LNA.

If you are not certain about the design of your down converter, go back and check the instruction manual. As a last resort, carefully take the down converter apart and see if you can find a fuse. If you don't find one there, and you are baffled by all of the funny wires and parts, stop right there and box it up.

However, let us assume that we have power coming out of the down converter 'input' and we feel quite certain the LNA is getting power. Let's not take anything for granted yet.

Between the down converter and the LNA we have that 'passive' piece of coaxial cable; on both ends we have a type N connector, and in between we have some nomenclature such as RG-213, RG-214 or even (shudder) RG-8.

Get yourself to the LNA and carefully unscrew the type N connector that connects **into** the LNA. Now get the black/ground side of the meter to the outer/shield part of the connector and then **very-very carefully** touch the red/positive lead of the meter to that tiny **center**



VOM/ Volt OhmMeter is handy test device that allows you to quickly check the DC voltage from your receiver/down converter/LNA system. And, it also helps you check for 'continuity' of a cable line (see text). Radio Shack has them. Digital (left) and analog (right) types are shown.

pin inside of the type N connector.

Be careful here.

There is a metal ring that surrounds the tiny center pin-tip. That ring is ground! **Don't allow** the red meter lead probe to touch **both** the center pin **AND** the circular shield around the tip at the same time. Instant short circuit and instant fuse blowing time.

Humm. Voltage here also? That tells us that the LNA is getting power. Now, why won't this darn thing work!

Remember that we said the **first** thing we had to do was to check out the system powering. We have now done this, and unless we found YOUR problem someplace along the way, we still have a defective terminal. Where to next?

This might be a good time to step back and analyze what the most common defect is after power. Cabling is the answer.

Now, we know that certain segments of the cable are OK. There was power from the demodulator all the way to the down converter and the LNA. That tells us that any cable connecting the three together is good. And this eliminates the RG-213/4 between the down converter and the LNA. In some receiver designs, it would also eliminate the RG-59/U connecting the down converter to the demodulator/receiver. But not all.

Not all receivers send DC operating voltage for the down converter and LNA through the **same coaxial cable** as carries the 70 MHz signal back indoors from the down converter. In fact, most now days use a separate piece of RG-59/U ('Siamese' or separate), **or**, some other power carrying wire between the two. This could still leave the RG-59/U between the down converter and the demodulator/receiver **if** it is used for **nothing but** carrying the IF signal indoors.

Now, how do we check that?

First we take both ends loose and inspect them. An 'F' fitting is difficult to screw up, but it can be done. One of the most common mistakes is to leave a tiny piece of the braided (outer shield) in where it can touch the inside copper center conductor. That will short the two 'sides' together and even if the RG-59/U is not carrying any DC power, that short (both sides touching) will ruin the 70 MHz IF signal trip inside.

OK here? Next we have to figure out a way to test the RG-59 for 'continuity'. That's a fancy word for determining if the cable is one whole piece, unbroken, from the down converter F fitting inside to the back of the receiver.

If you have your trusty VOM (volt ohmmeter) handy, there are two quick ways to do this. One involves pulling a short 'alligator clip lead' out of your tool bag and the other involves having a 9 volt 'transistor' battery handy. One at a time.

SERVICE/ continues page 14

AVCOM® NEW Product Update

NEW from AVCOM

Toll-free OrderLine

AVCOM • 500 Research Road • Richmond, VA 23236 • 804-794-2500



COM-2A



- * Attractive Styling
- * Scantune
- * Tunable Audio with wide and narrow IF switch
- * Comprehensive Remote Control (Standard with COM-2A, Optional with COM-2B)
- * Sensitive Signal Strength Meter
- * Remote Downconverter
- * AVCOM Quality at a Low Cost



COM-2B

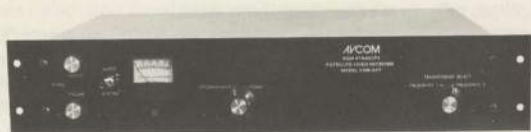

COM-20T

AVCOM's COM-20T High Stability Satellite Video Receiver is the answer to your need for a highly stable and reliable receiver for cable, private cable, radio stations, TV stations, BIZNET, News, Weather & Music Services, and other dedicated applications. The COM-20T can be factory or field adjusted to a particular transponder and will

remain on frequency without attention. The COM-20T is normally supplied with a remote downconverter and tunable audio. Optional configurations include fixed-tuned audio, internal downconverter, and downconverter switching for multi-channel capability. Styling matches AVCOM's popular series of rack mount receivers.



COM-66T

The COM-60 Series for Cost-Effective Multi-Channel Installations

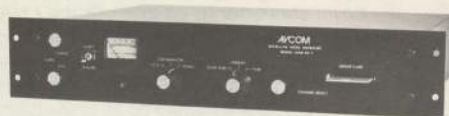

COM-65T

- * Commercial Quality
- * Compatible with SA's 6650 system
- * Rack Mount, standard
- * Double Conversion
- * Flexible Downconverter (Use any degree and brand LNA)
- * High Stability



AVCOM's Toll-free OrderLine 800-446-2500 (Orders Only)

All other inquiries phone 804-794-2500.

STARDUSTER

Compact, Complete and Powerful

Common sense and good engineering have been combined to make the Starduster one of the most powerful and popular 8 foot antennas available today. Its deep dish, one piece construction provides optimum reception by utilizing a shorter focal point, thus reducing terrestrial interference.

Constructed of high quality aircraft-type aluminum, its smooth satin finish will deliver crystal clear reception from all orbiting satellites, along with many audio services.

The Starduster is mounted on a 360° swivel polar-mount which is constructed of heavy gauge steel. The polar mount is coated with a ceramic-type paint for years of maintenance-free service.

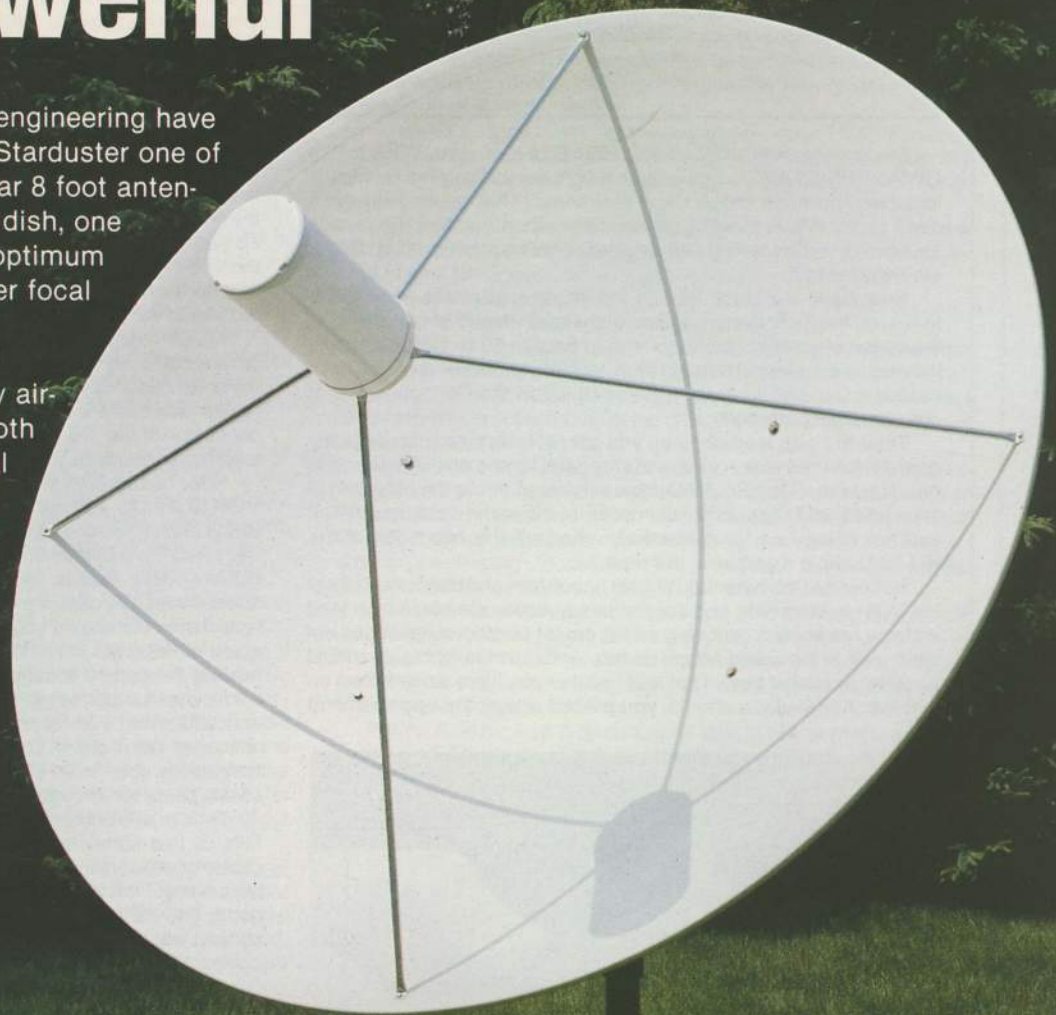

For more information on becoming a Starduster distributor or dealer, please write or call today.

 **DELTA**[®]
SATELLITE CORPORATION

\$499.

QUANTITY PRICING AVAILABLE

SERVICE/ continued from page 11

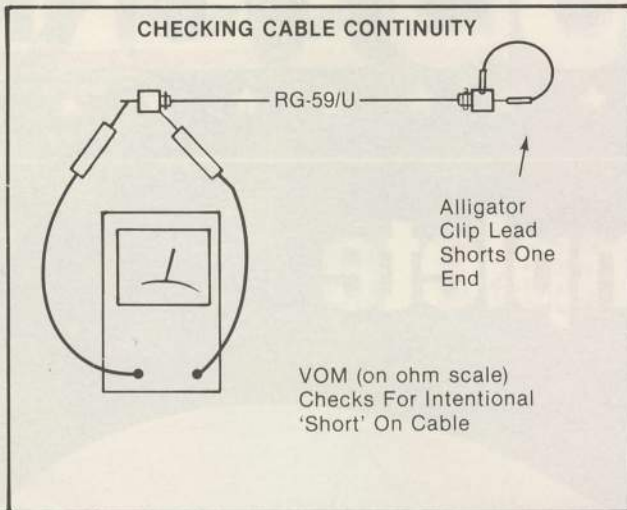

Disconnect both ends of the RG-59/U. Set your VOM to the OHMS/RESISTANCE scale and touch the black and red leads together. The meter should show 'zero ohms'. That means you have a dead short. Which is what you do have when you touch one side (positive or red lead) to the other side (negative or black lead). Good, the meter works.

Now place the black lead to the shield side of the coax (outer ferrule on the F connector) and carefully touch the other meter lead to the center pin/center conductor wire in the RG-59/U. Nothing should happen on the meter. It should read 'infinity', or "lots of ohms". That's because you should have a piece of cable that is 'open', or not connected, at both ends.

Take the clip lead (the one you got at Radio Shack in the pretty green/yellow/red wire colors) and carefully clip one end of one lead to the shield side of the RG-59/U. Now very carefully clip the other end of the same lead to the center conductor of the same cable end. What you are doing here is deliberately 'shorting' the two sides of the RG-59/U cable together at one end.

Hotfoot it to the other end (inside or outside) and carefully connect the VOM to the shield and the center conductor. Be careful the lead end you are holding delicately on the center conductor lead does not short over to the shield as you do this. And read the 'ohms'. It should be 'zero' or almost zero. That tells you that you have a dead short on that line. And well you should; **you placed one at the opposite end**

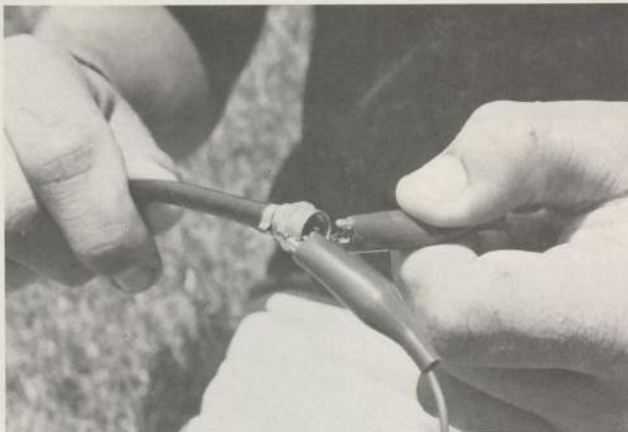

CLIP LEAD allows you to check the intactness (continuity) of a coax line by deliberately 'shorting' one end and then measuring the presence of the short at the opposite end of the line.

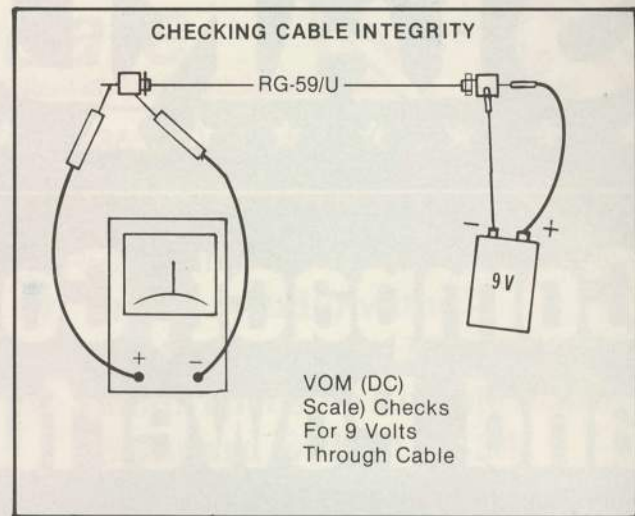

with the clip lead!

Or maybe you would prefer to use a 9 volt transistor battery to test for 'continuity'. Here's how we do this. Have a battery already made up in your tool kit. Take a clip lead and solder or attach a bare wire end to the positive terminal on the battery, leaving free the other end with the alligator jaws clip on it. Do the same thing with the opposite (+ or -) terminal on the battery. Now you have a handy way, using the two alligator-jaw clip leads, to attach the 9 volt battery to something exterior to the battery.

Attach the ground (negative) side to the shield portion of the coaxial cable (be sure you are connected to the shield **and not just** to the small metal 'O' ring that may be insulated from the shield with the rubber jacket on the cable). Attach the positive clip lead to the center connector of the RG-59/U. Be careful that you don't short the two together or you'll have a fried battery in a hurry!

Now, hotfoot it to the opposite end of the cable and switch your VOM to the **DC voltage scale**. Clip the black test meter lead to the shield (again, be sure you are onto the shield and not the metal O ring that could be insulated from the shield with the rubber jacket) and the positive meter lead to the center conductor. You should read just about 9 volts. Or, almost precisely the same DC voltage as you would read if your connected your meter to the battery direct. In effect, the piece of RG-59/U is an 'extension' on your clip leads and you are reading the battery voltage 'by remote control'.

Now let's suppose you found the resistance (clip lead across one end; as a short) was not zero ohms; but something higher. Say it was 'infinity' or lots of ohms. That tells you that someplace along the cable, the cable is 'open'. One side (or both sides) of the cable have 'broken'. Like in being cut through. Or suppose the meter reads something like 40 ohms or 400 ohms. Not zero, certainly, and not infinity either. That tells us that someplace along the coax run we have a 'squashed' cable; one that is trying to be shorted out, but not quite making it to zero ohms. First be sure your on purpose short at the far end is still good; that the alligator leads have not jumped off or lost pressure contact with the cable. If that checks out, you have a bad piece of cable.

Or, let's assume the battery check reads not 9 volts (or whatever the battery checked out with when you connected your VOM to it 'direct'), but maybe 6 volts. That's because someplace along the way we have a 'load' on the battery; something is taking current out of the battery. In theory, only the meter at the very end should be doing that and the meter draws no real current. Something along the way (like a partially broken cable, a splice fitting that has gotten water in it and caused a partial ["high impedance"] short) is soaking up the current from the battery. And drawing the battery voltage down. Again, that tells you that you have a bad piece of cable or a bad splice along the way.

Installing RG-59/U, especially if you run it between the dish and the receiver inside a protective piece of 1/2 to 1 inch PVC conduit, is

not difficult to do. However, if you have to snake your cable in through the side of a building, under windows, or through some tight places, you can damage the cable (by ripping tears in the outer jacket). A damaged cable can 'leak' moisture into the cable. And moisture, over a period of time, will 'contaminate' the cable. Where the moisture gets inside, it turns that bright copper shield a dull, flakey 'green' color. And that spot becomes a high resistance to the flow of electricity. Bad news to be sure.

There could be worse news. Maybe everything checks out fine up to this point. OK, now where do we look?

There are three obvious possibilities:

- 1) The LNA has quit working;
- 2) The down converter has quit working;
- 3) The demodulator/receiver has quit working.

Original equipment manufacturers tell us that a surprisingly high number of TVRO receivers sent back for repair **do not**, in fact, **have anything wrong with them!** That means that a fair percentage of the dealers are doing 'massive change outs', or field unit replacements, when they encounter problems. The same OEMs advise that after a while, opening receiver boxes on units returned for 'warranty repair', and spending a half hour or more of valuable bench time determining that everything is fine, gets very old. Some have even instituted 'charges' for **non-repair-warranty work**; in other words, if you send back to them a receiver that you are **not certain is bad**, and they find out it is working OK, you can expect to get a repair bill (or the unit back COD for repair time lost). That should tell you that perhaps it is better to spend a few extra minutes **being certain** that a receiver (or LNA or down converter) **is bad** before you box it up and shoot it back to the factory.

Ideally, you could check out each of the three parts before deciding they were bad. Unfortunately, there is no inexpensive test equipment about that will allow you to do this. Only Newton Electronics (*) offers a full TVRO test set and it is priced up there like one of the old style AVCOM super deluxe receivers; so not many installers can yet justify such an instrument.

So we resort to 'tricks'; tricks that may work for some people all of the time and for some more people some of the time. The bottom line is that checking a TVRO all the way from antenna surface through the LNA, down converter and to the output of the receiver is not yet a simple task. You have to use some basic logic and deduce what is **probably** wrong; not quite certain you can **prove** what is wrong.

Probably the fastest way to check out the LNA is to replace it. With one you KNOW is good. Many installers keep an older, cheaper, 120 degree unit in their tool kit for just this purpose. They use it a couple of times per week; they know it is good. Not the best, but it does work. Why not just pop open a **new** LNA box and stick a new one on? Perhaps you have never had an LNA that was bad straight out of the box! Now **that** will cost you a half day or more . . . you swap out the suspected LNA with a brand new one and still no people on the screen. Obviously it is not the LNA; right? Uh-huh. Several hours later you will be back trying a third LNA and be madder than hops to find out it was the LNA all along!

There is another way but it does not work all of the time with all systems. It is called an incandescent light bulb. The kind you have over your desk in your shop. On the end of an extension cord you have a light bulb socket. With a helper, you stick the 75 to 100 watt standard, incandescent bulb up in front of the LNA. Tell your client you are checking inside the LNA/feed for 'bugs'(!). Then watch the screen.

The light bulb is (or should be . . . not all are and that's the danger) a terrible 'noise source' at C band (4 GHz). Just holding it in front of the feed should produce a severe case of sparklies on the screen. Obviously you want to keep one hand-selected, 'noisy light bulb', in your tool kit having proven that you have such a light bulb before you get on the job and ask the lady of the house if you can borrow the kitchen light for few minutes!

No noise . . . and you know the bulb is a (good!) noise generator at 4 GHz? Doesn't prove much of anything. Why? Because if the down converter was bad, the noisiest light bulb in the world won't make a

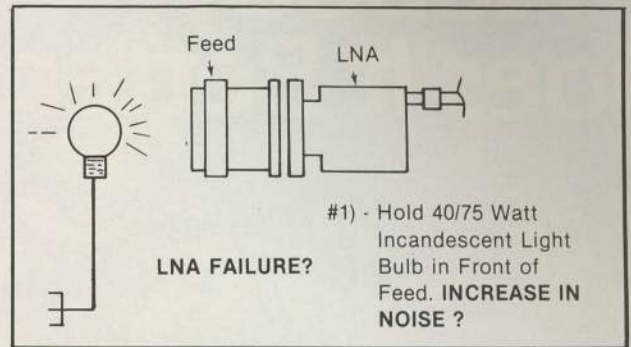

dent on the screen.

Lots of noise? Now you are getting someplace. That tells you the LNA (and down converter and receiver and all cables) works. So why don't you see people on the screen? Maybe some kid in the neighborhood re-adjusted your elevation jack for you and you are looking a few degrees off of the orbit belt!

So here's a situation where even swapping a good LNA for another good LNA wouldn't lead you in the right direction; you'd suspect something other than the LNA, when it was a mis-adjusted antenna all along.

Let's keep going however and assume we have no noise from the light bulb and we've swapped LNAs also. Still no people on the screen. That begins to suggest our problem is further down the line.

Maybe. Maybe not.

Before we leave the LNA, what about the feed?

Let's start by crawling around the front and looking up **into** the feed. If you have one of the older feeds without a rotation system built in, you should be able to see through the feed to the gold/silver plated 'feed stub' inside of the mouth of the LNA. No small critters could have taken up residence in there. Mud dobbies are a no-no.

If your customer's feed is one of the current rotation systems, using a small probe (piece of wire bent into a crazy shape) up inside of the 'mouth' of the feed, we have a more difficult analysis ahead of us. If the mouth of the feed is covered with a piece of cellophane, you may be able to peer through to see the bent wire probe behind the cover. Sometimes they corrode and fall off! Still there? Good.

Just to be sure, let's take the bolts that hold the feed to the front mouth/flange of the LNA off and expose the bare open face of the LNA. Just for fun, check the receiver again with nothing left in place but the LNA; sans scalar feed. Any signs of people? Even weak people? Nope? We'll proceed.

Put the feed back on (you should be able to see 'something' in the way of a WEAK picture **with the scalar feed removed** and if the feed is somehow bad, taking it off even without replacing it with another [new] one will tell you if the feed has gone south).

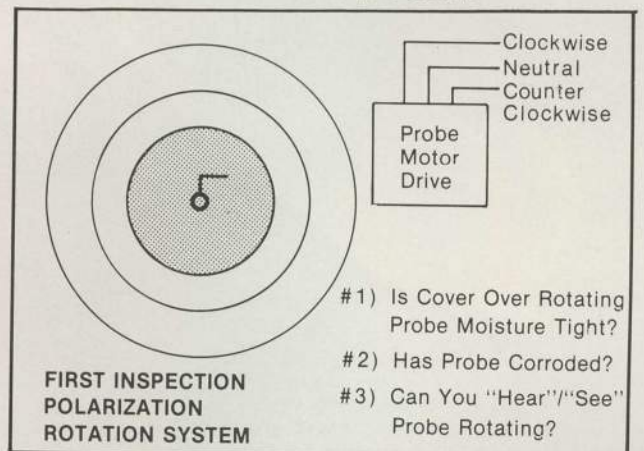

* — Newton Electronics, 2218 Old Middlefield Way / Suite 1, Mountain View, Ca. 94043.

We'll continue this in the September issue.

Nobody Does It Better.

Owning a satellite television system opens up a whole new world of entertainment and educational opportunities for your family. Satellite television means more great Movies, Sports, Specials, Childrens Programs, News, Weather, Business, Education and Adult Programs than you can imagine. Examine a satellite TV program and you'll see what we mean.

The design of our new 2.8 meter model is based on the same proven engineering concepts as our original 3.8 meter antenna. We've refined the shape of the ribs and changed the hub to achieve greater structural integrity and less weight. Our welded Rib & Ring truss system shapes the expanded aluminum mesh into a true parabolic shape. Because wind resistance through the mesh is so much less than a solid dish, and the heat dissipation far greater, a Paraclipse system will remain true in the worst environments. Our ingenious polar mount allows you to change satellites in seconds, simply and accurately.

With the recently enacted 2° satellite spacing, our 2.1° beam width will give clear, sparkle-free reception, while less accurate antennas will become obsolete.

When you shop for a satellite television antenna, take a close look at the equipment and ask lots of questions. Keep in mind that the soonest you'll know the true cost of any system is after you've seen the end of it's service life. Try to separate the facts from the promises and go with a reputable manufacturer.

Only after you know something about the various solutions will you be able to make an intelligent choice about them.

© Copyright 1983 Paradigm Mfg.



Paraclipse 2.8 meter